

注1. 本キット品は、KW04ハーネス用の交換部品である。

Note 1. This kit is a replacement part for the KW04 harness.

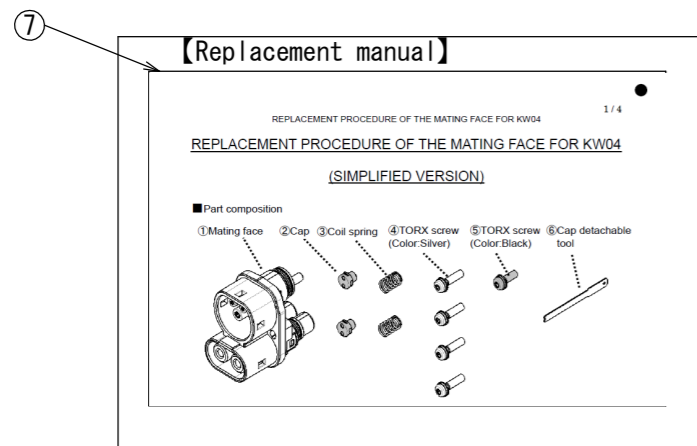

【Mating face】

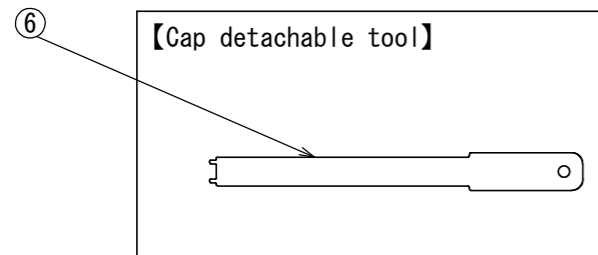
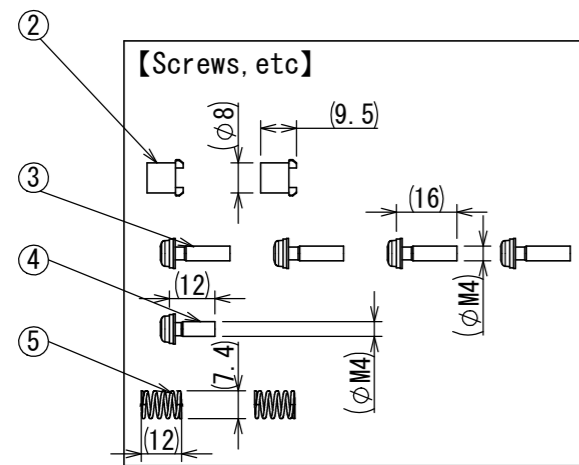
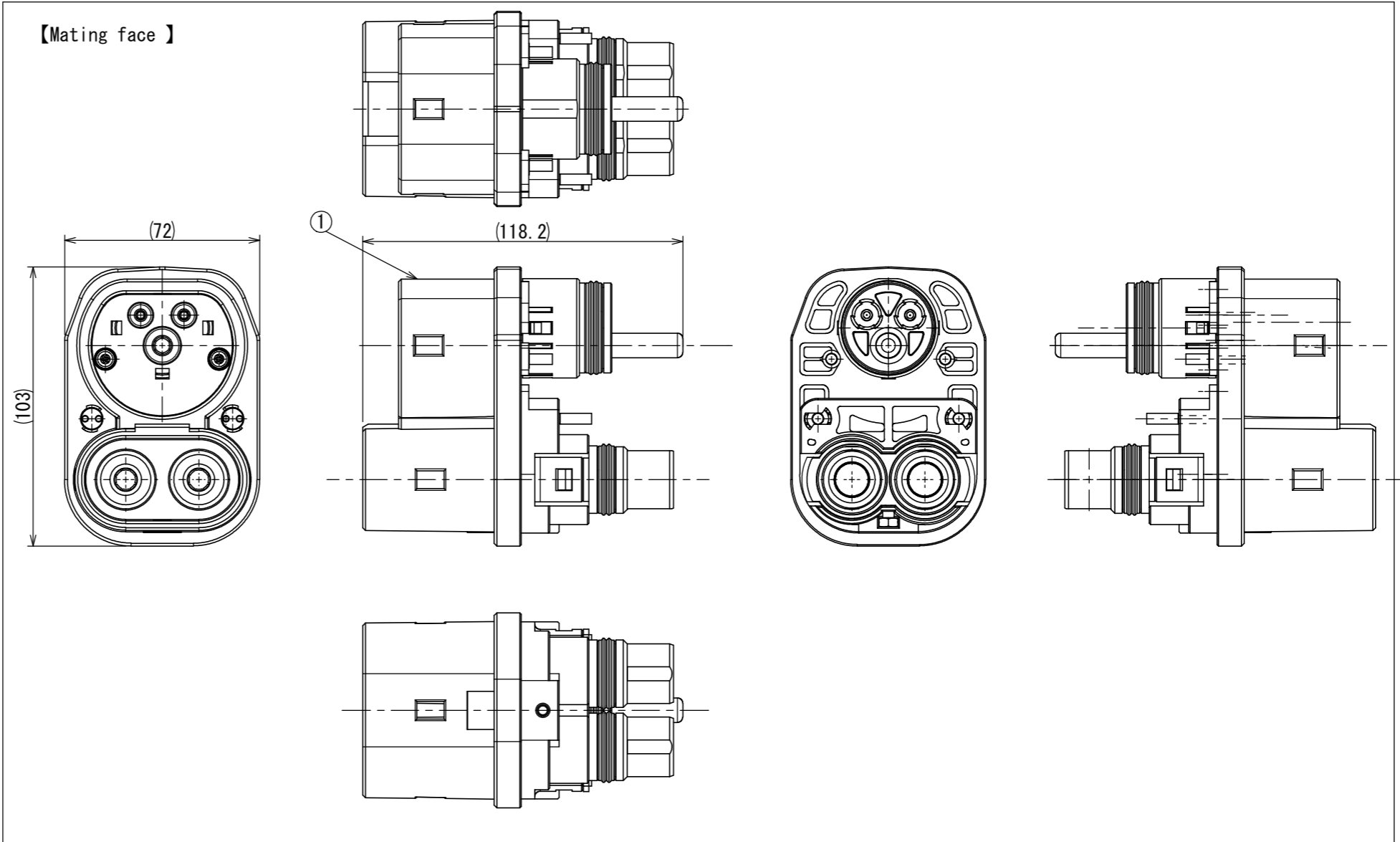

符号 NO.	名称 DESCRIPTION	個数 QTY.	材料 MATERIAL	仕上 FINISH	備考 REMARKS
7	Replacement manual	1	-	-	-
6	Cap detachable tool	1	STAINLESS STEEL	-	-
5	Coil spring	2	STAINLESS STEEL	-	-
4	TORX screw (Color:Black)	1	STAINLESS STEEL	Color:Black	-
3	TORX screw (Color:Silver)	4	STAINLESS STEEL	Color:Silver	-
2	Cap	2	SYNTHETIC RESIN	-	-
1	Mating face	1	-	-	-

仕様書 (SPECIFICATION) JACS-40204-01, -02	第1版 (ORIGINAL DATE) 12/NOV/2019	尺度 (SCALE) 1:2	シリーズ (SERIES) KW	日本航空電子工業株式会社 JAE
製図 DR. —	担当 CHK. K. KUGOU	名称 (TITLE) KW04 REPLACEMENT KIT	JAE JAPAN AVIATION ELECTRONICS INDUSTRY, LTD.	
一般公差 (GENERAL TOLERANCE) 寸法 (DIMENSION) × ±0.8 ×× ±0.4 ××× ±0.1 ×××× ±	角度 (ANGLES) ×° ± ×°×' ±	査閲 APPD. —	承認 APPD. T. OYAKE	図面番号 (DRAWING NO.) SJ121489
単位 (UNIT) : mm		質量 (MASS) —		版数 (VER.) 1

WISDOM承認 2019/12/17